

PhaseCam® IR

4D Technology

Dynamic Infrared Twyman-Green Interferometers

Instantaneous Acquisition

PhaseCam® IR dynamic laser interferometers operate at wavelengths of 3.39 μm or 10.6 μm . With simple, motorized controls these systems are ideal for measurement of focal optical systems such as concave telescopes and lens systems, and for testing afocal components such as flat mirrors and collimators.

The dual-mode PhaseCam can operate in standard temporal mode, or in vibration-insensitive mode utilizing Dynamic Interferometry®. The PhaseCam IR incorporates a single camera, high-speed optical phase sensor that makes a wavefront measurement in less than 1 millisecond—hundreds of times faster than a temporal phase shifting interferometer. Because acquisition time is so short, the PhaseCams can be used under almost any conditions without vibration isolation or turbulence control. This insensitivity to environmental factors makes the PhaseCams ideally suited for use on the production floor or in clean rooms.

Complete Measurement System

The PhaseCam IR is a turnkey instrument that includes the interferometer, 4Sight™ advanced wavefront analysis software, and complete, high-speed computer system. Samples with any reflectivity from 10% to 100% can be measured without the use of an external attenuator.

Industry Leading Analysis, Standard

4Sight wavefront analysis software features a user-friendly interface with unmatched simplicity, analysis features and graphical displays. The Measurement Console display aids alignment and execution of single, averaged, burst or continuous data acquisition. The Measurement Flow interface lets you visualize the entire measurement data flow, from raw acquisition through masking, reference subtraction, terms removal, etc. The unique Measurement Stack enables complex data manipulation and comparison. Zernike, Seidel, geometric and diffraction analyses are easy to perform. Comprehensive data sharing capabilities let you read, write, save and print from most file types, including MetroPro IDL®, MatLab®, Opticode®, Vision®, HDF5® and CodeV®. Generating phase movies to characterize deforming surfaces and moving parts is simple and straightforward.

Accessory Optics

Diverger lenses for measuring spherical elements, beam expanders for measuring afocal optics and corner cubes for alignment are all available for the PhaseCam IR.

FEATURES

- Vibration Insensitive Dynamic Operation
- < 1 millisecond Data Acquisition Time
- 3.39 or 10.6 μm Wavelengths
- Outstanding Data Analysis and Visualization Software

APPLICATIONS

- Quality Verification of IR Optical Components
- Focal Optical Systems
- Afocal Components



PhaseCam IR

PhaseCam[®] IR

4D Technology

Specifications

Configuration	PhaseCam IR
Description	Turnkey vibration insensitive dynamic Twyman-Green interferometer
Acquisition Mode	Dynamic or temporal phase shifting
Alignment Mode	Visible alignment laser
Wavelength	3.39 μm or 10.6 μm
Maximum Output	Test laser: < 4 mW at 3.39 μm , < 400mW at 10.6 μm Alignment laser: < 45mW at 658 nm
Maximum Cavity Length	> 60 m
Beam Diameter	14.0 mm collimated
Polarization	Linear
Pupil Focus Range	± 12.5 mm
Pupil Magnification	1x to 3x
Camera	320 x 240 or 640 x 512 pixels for 3.39 μm model; 320 x 240 pixels for 10.6 μm model
Data Array	User Selectable full, half, quarter data arrays
Motorized Controls	Zoom, Focus, Path Match, Beam Attenuation, Reference Beam Block
Computer System	Minimum Dual Core 2.4 GHz processor, 4 GB RAM, 320 GB hard drive CDRW, DVDRW, 22 in LCD monitor, keyboard, mouse
Operating System	Windows XP [®]
System Software	4Sight [™] with User Manual Instantaneous Phase Shifting data acquisition Reference generation, subtraction, data averaging, masking 2D and 3D surface maps Zernike / Seidel / Slope / Geometric / Fourier Analysis Fiducial aided data set mapping HDF4 / HDF5 data format standard, others supported Absolute sphere, prism & corner cube analysis Multiple sub-aperture analysis Upgrades – free during warranty period
Physical Envelope	< 82.2 x 50.8 x 26.1 cm (32.4 x 20 x 10.3 in)
Weight	< 54 kg (120 lbs)
Power consumption	< 750 Watts
Temperature Range	Operational: 60–80° F, non-condensing Storage: 30–100° F, non-condensing

Warranty One Year, limited, on-site system installation and operator training

Options

Beam Expanders	Range of expanders available on request
Diverging Lenses	Range of lenses available on request

System Performance

Acquisition Rate	> 10 frames/sec display; 4 interferograms/frame > 25 frames/sec max data acquisition with post processing*
Minimum Exposure	30 ms; 500 μsec for 3.39 μsec High Res model
Sample Reflectivity	10 to 100%
RMS Repeatability	< $\lambda/2000^{**}$
RMS Precision	< $\lambda/1000^{***}$

* In dynamic spatial carrier mode

** One sigma for RMS of 10 data sets of calibration mirror, each data set being an average of 16 measurements.

*** Average RMS of the difference of 10 data sets between measured surface and the calibrated surface. Each data set being an average of 16 measurements. Calibrated surface is the pixel by pixel average of 10 measurements of calibration mirror.

All specifications subject to change without notice.

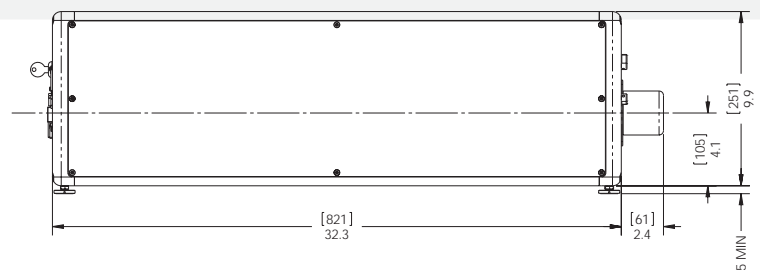
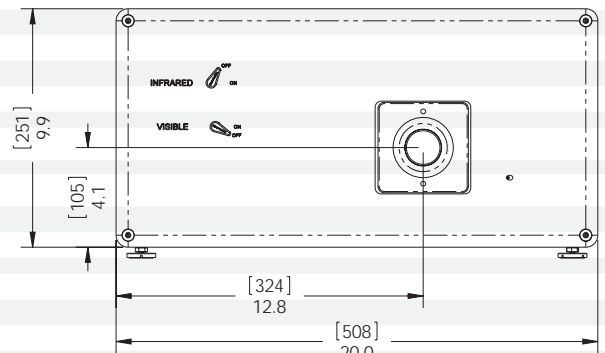

PhaseCam and Dynamic Interferometry are registered trademarks of 4D Technology Corporation. MetroPro IDL, MatLab, Opticode, Vision, HDF5, CodeV and Windows XP are registered trademarks of their respective owners.